

REVISIONS			
REV	DESCRIPTION	DATE	APPROVED
--	--	--	--

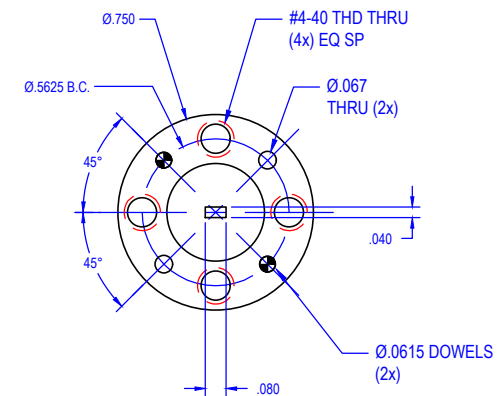
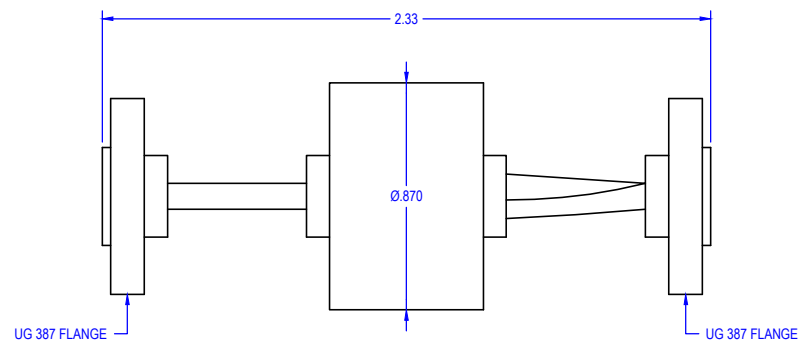
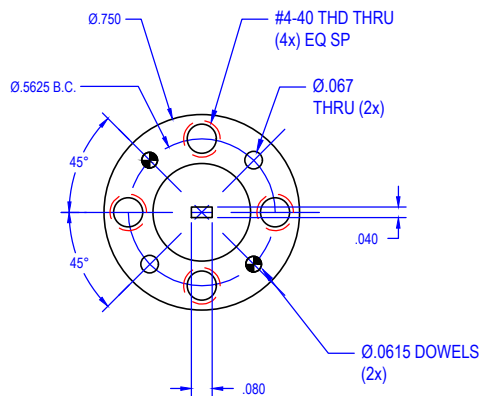
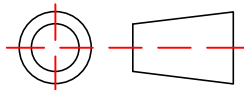

QTY	PART NUMBER	DESCRIPTION		ITEM	
--	--	OUTLINE		--	
UNLESS OTHERWISE SPECIFIED		 <p>THIRD ANGLE PROJECTION</p> <p>DRAFTING: MRN</p> <p>APPROVED: M.S.</p> <p>DATE: 2/23/2012</p>			
ALL SURFACES $\sqrt{32}$					
DIMENSIONS ARE IN INCHES					
TOLERANCES ARE: DECIMALS: .1234 +/- .0005 .123 +/- .005 .12 +/- .01 ANGLES: +/- .5 DEGREES					
ALL THREADS TO BE 2A OR 2B		SHEET NO.	OF	SIZE	DWG NO
REF DWG# --		1	1	A	21716
		<b>Mi-Wave</b> Millimeter Products Inc.		TITLE <b>115F/387</b> <b>OUTLINE</b>	