

REVISIONS			
REV	DESCRIPTION	DATE	APPROVED
--	--	--	--

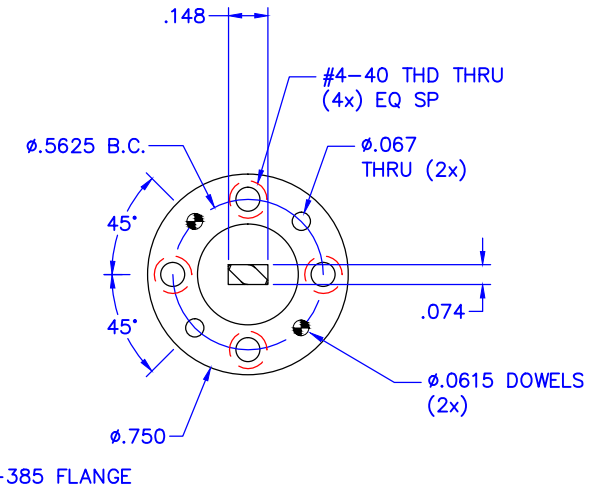
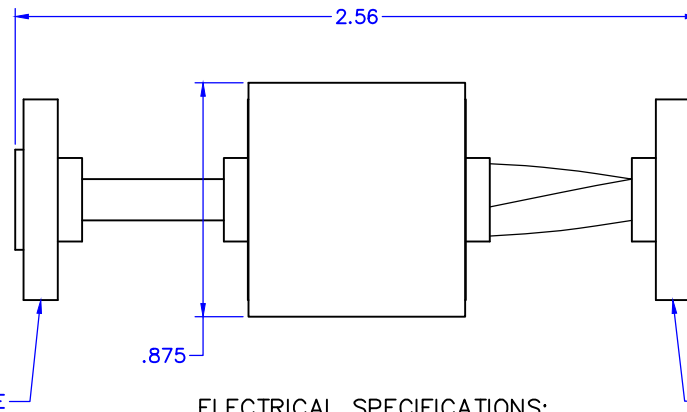
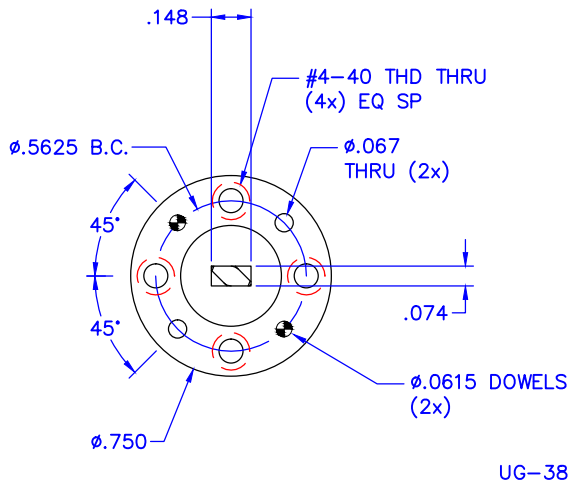

ELECTRICAL SPECIFICATIONS:
 INSERTION LOSS: 1.7 dB NOM
 ISOLATION: 25 dB NOM
 VSWR: 1.30:1

QTY	PART NUMBER	OUTLINE		ITEM
		DESCRIPTION		
	UNLESS OTHERWISE SPECIFIED ALL SURFACES $\sqrt{32}$	 THIRD ANGLE PROJECTION	Millimeter Products Inc.	
	DIMENSIONS ARE IN INCHES TOLERANCES ARE: DECIMALS: .1234 +/- .0005 .123 +/- .005 .12 +/- .01 ANGLES: +/- .5 DEGREES		TITLE 115V OUTLINE	
	ALL THREADS TO BE 2A OR 2B	DRAFTING: MRN	SHEET NO. OF SIZE DWG NO 1 1 A 21508	
	REF DWG# --	APPROVED: M.S. DATE: 11/18/2011		