

REVISIONS			
REV	DESCRIPTION	DATE	APPROVED
--	--	--	--

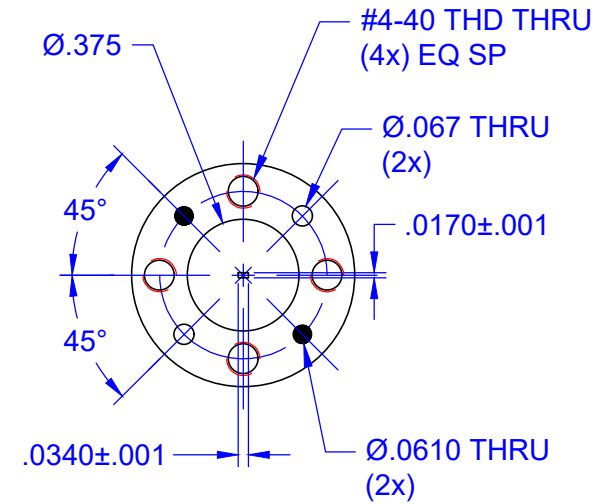
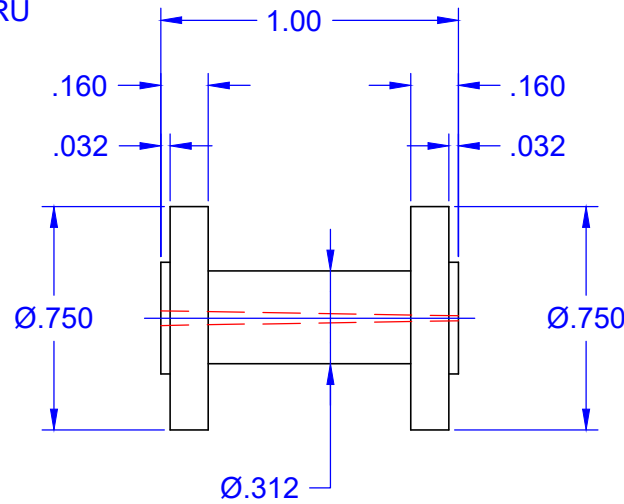
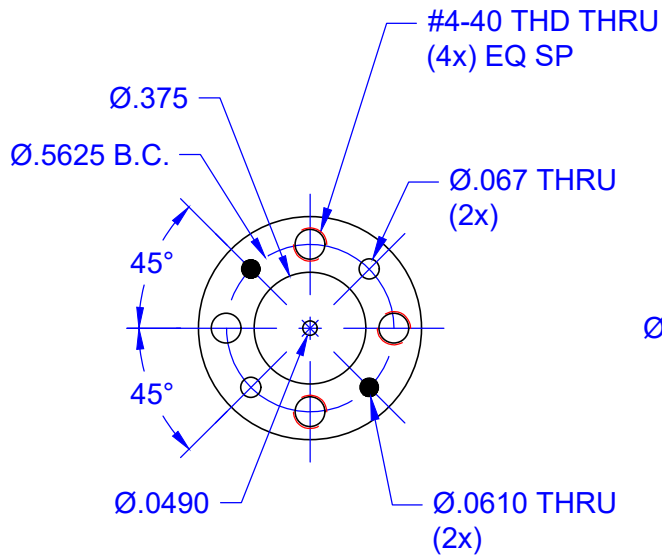
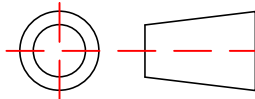

--	--	MATERIAL: 1/2 HARD BRASS		--
QTY	PART NUMBER	DESCRIPTION		ITEM
UNLESS OTHERWISE SPECIFIED ALL SURFACES $\sqrt{32}$		 THIRD ANGLE PROJECTION		Mi-Wave Millimeter Products Inc. TITLE 284J-.049/387 MACHINE DWG
DIMENSIONS ARE IN INCHES TOLERANCES ARE: DECIMALS: .1234 +/- .0005 .123 +/- .005 .12 +/- .01 ANGLES: +/- .5 DEGREES				
ALL THREADS TO BE 2A OR 2B		SHEET NO.	OF	SIZE
REF DWG#--		1	1	DWG NO
				A
				23712