

REVISIONS			
REV	DESCRIPTION	DATE	APPROVED
--	--	--	--

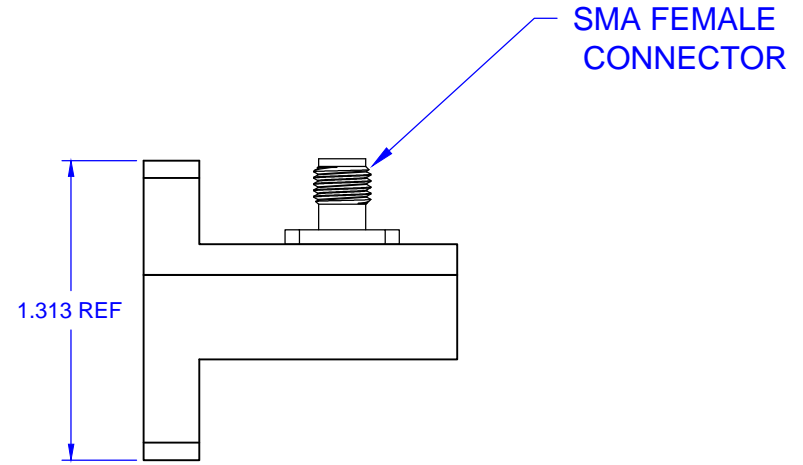
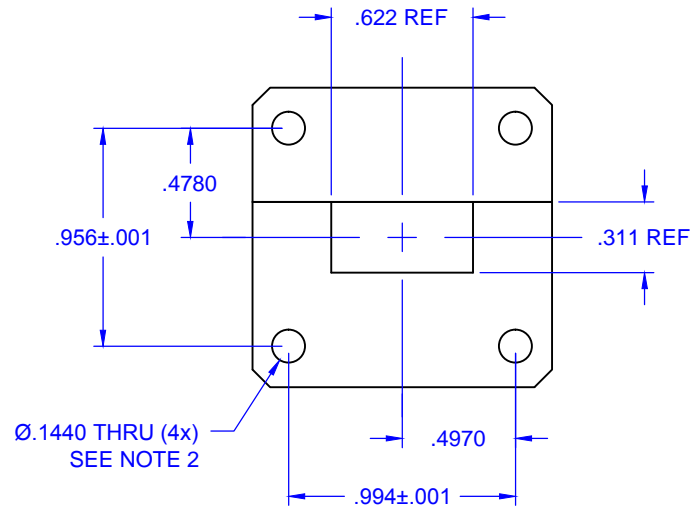
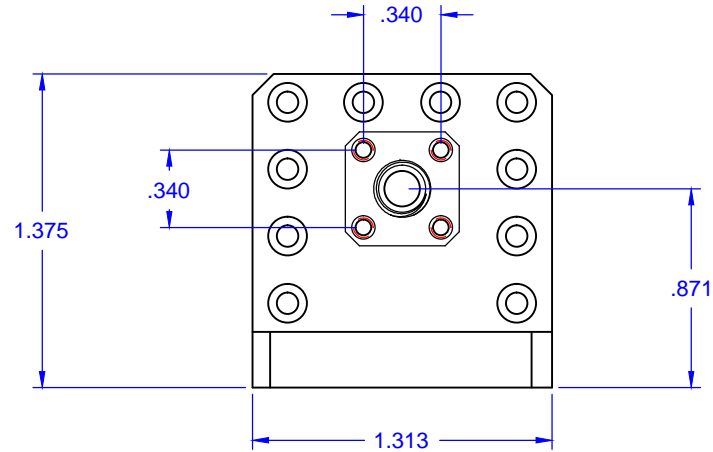

UNLESS OTHERWISE SPECIFIED ALL SURFACES $\sqrt{32}$	 THIRD ANGLE PROJECTION	Mi-Wave Millimeter Products Inc.	
		TITLE 410KU/419_SMA OUTLINE	
DIMENSIONS ARE IN INCHES TOLERANCES ARE: DECIMALS: .1234 +/- .0005 .123 +/- .005 .12 +/- .01 ANGLES: +/- .5 DEGREES	DRAFTING: JV APPROVED: M.S. DATE: 1-9-15	SIZE A	DWG NO 22695
ALL THREADS TO BE 2A OR 2B REF DWG# -----	SHEET NO. 1 OF 1		