

REVISIONS			
REV	DESCRIPTION	DATE	APPROVED
--	--	--	--

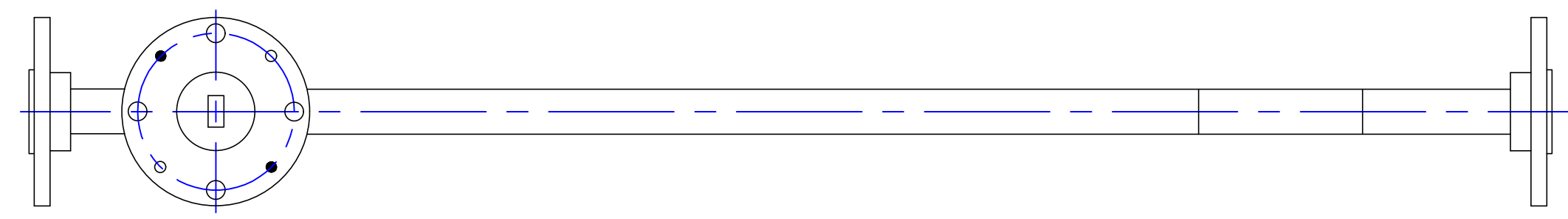
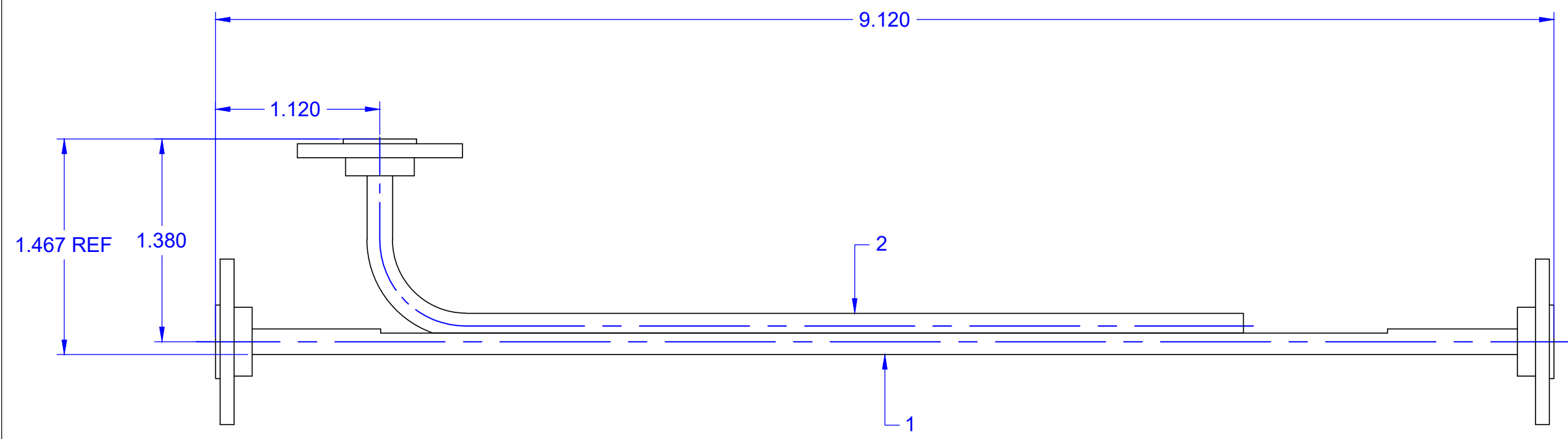
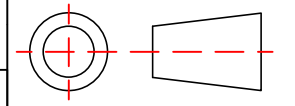

QTY	PART NUMBER	DESCRIPTION	ITEM
1	21663	U BAND LOAD	--
1	22742	CROSS ARM	2
1	22741	THRU ARM	1

UNLESS OTHERWISE SPECIFIED ALL SURFACES $32/\sqrt{\text{ }}$		 THIRD ANGLE PROJECTION	Mi-Wave Millimeter Products Inc. TITLE 560U/383 3, 6 dB FINAL ASSEMBLY	
DIMENSIONS ARE IN INCHES TOLERANCES ARE: DECIMALS: .1234 +/- .0005 .123 +/- .005 .12 +/- .01 ANGLES: +/- .5 DEGREES ALL THREADS TO BE 2A OR 2B				
REF DWG# --	SHEET NO. 1	OF 1	SIZE A	DWG NO 20023
ORIGINAL DWG# 20009d				