

REVISIONS			
REV	DESCRIPTION	DATE	APPROVED
--	--	--	--

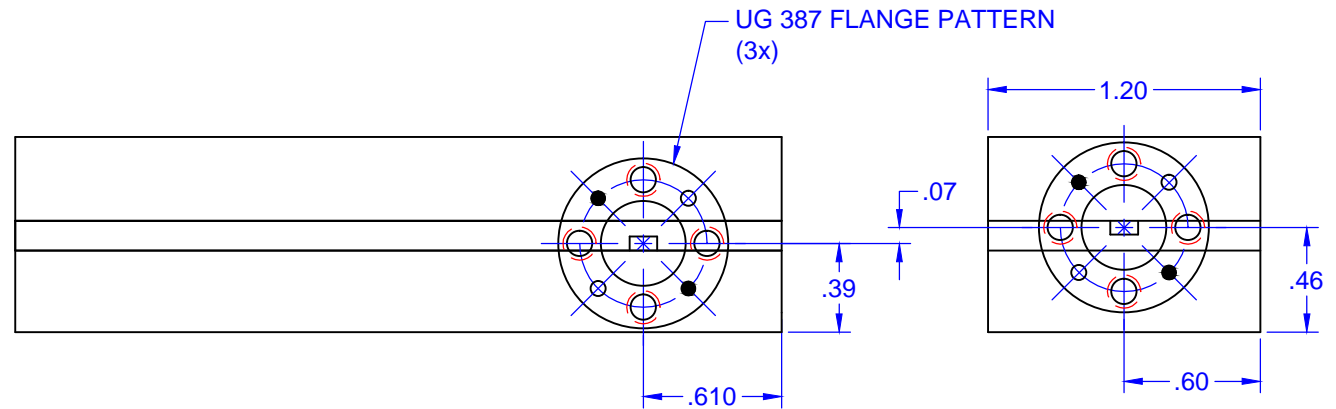
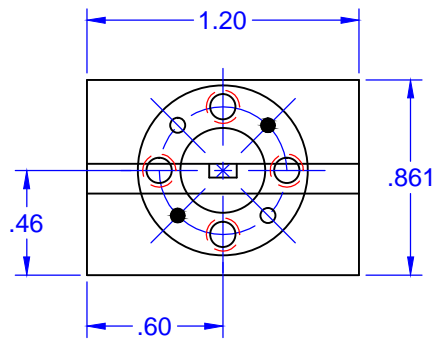
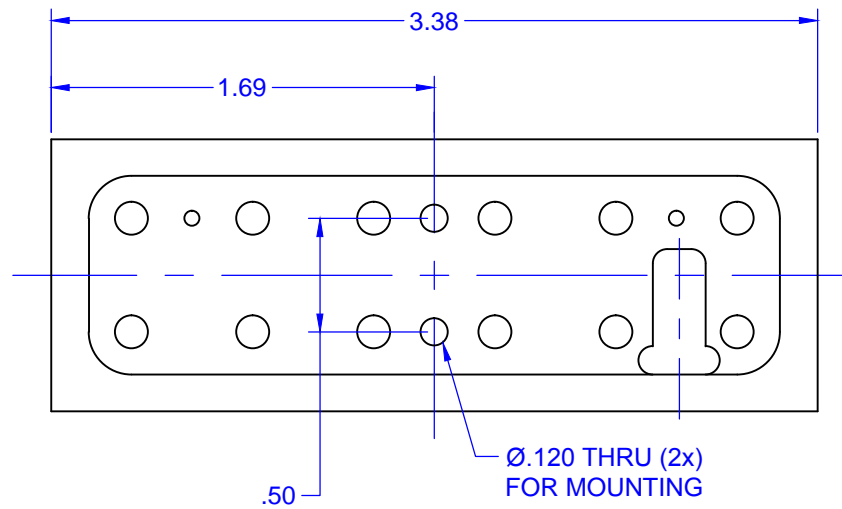

QTY	PART NUMBER	OUTLINE DESCRIPTION		ITEM
		Mi-Wave Millimeter Products Inc.		
UNLESS OTHERWISE SPECIFIED ALL SURFACES $\sqrt{32}$		THIRD ANGLE PROJECTION		TITLE
DIMENSIONS ARE IN INCHES TOLERANCES ARE: DECIMALS: .1234 +/- .0005 .123 +/- .005 .12 +/- .01 ANGLES: +/- .5 DEGREES		DRAFTING: K.S. APPROVED: M.S. DATE: 5/28/2014		561E/387 10-40dB OUTLINE
ALL THREADS TO BE 2A OR 2B REF DWG# 14333		SHEET NO. 1	OF 1	SIZE A
		DWG NO 22368		