

REVISIONS			
REV	DESCRIPTION	DATE	APPROVED
--	--	--	--

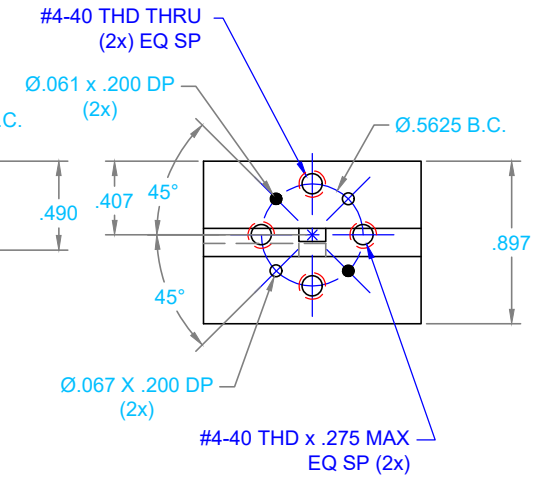
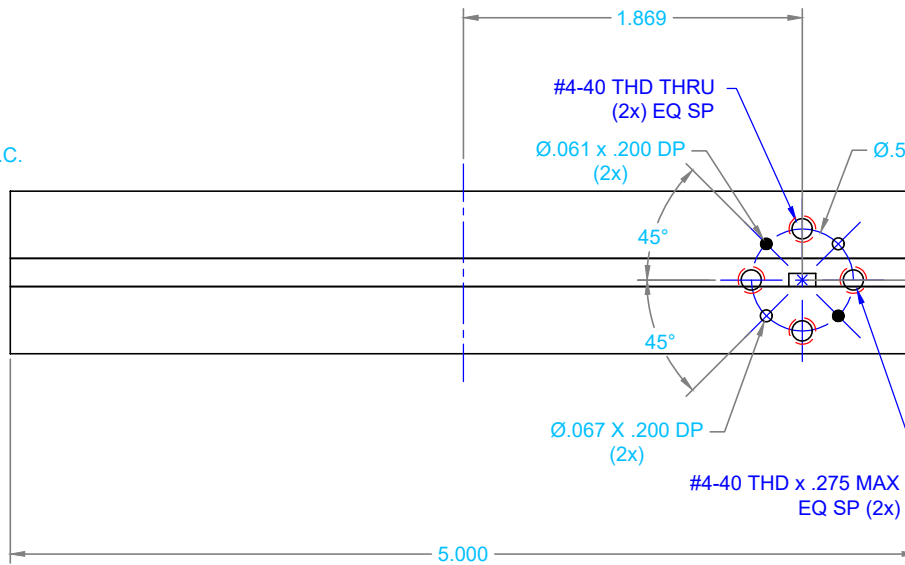
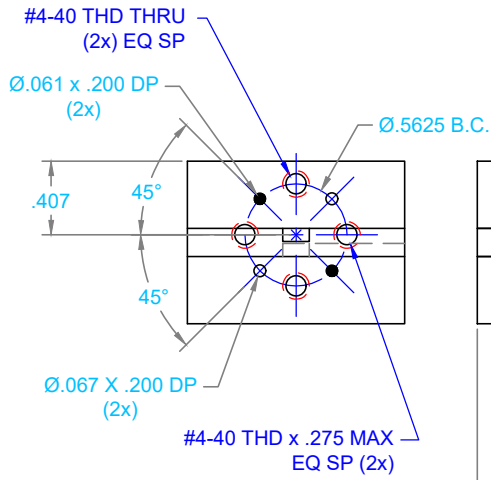
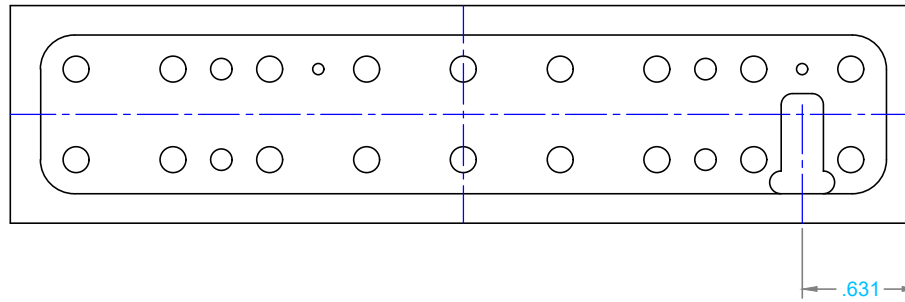

UNLESS OTHERWISE SPECIFIED ALL SURFACES $\sqrt{32}$	 THIRD ANGLE PROJECTION	Mi-Wave Millimeter Products Inc.	
		TITLE <b>561V 3 + 6dB/385 OUTLINE</b>	
DIMENSIONS ARE IN INCHES TOLERANCES ARE: DECIMALS: .1234 +/- .0005 .123 +/- .005 .12 +/- .01 ANGLES: +/- .5 DEGREES	DRAFTING: JV	SIZE	DWG NO
ALL THREADS TO BE 2A OR 2B	APPROVED: M.S.	A	22125
REF DWG# 14333	DATE: 10/28/2013		
	SHEET NO. 1 OF 1		