

REVISIONS			
REV	DESCRIPTION	DATE	APPROVED
--	--	--	--

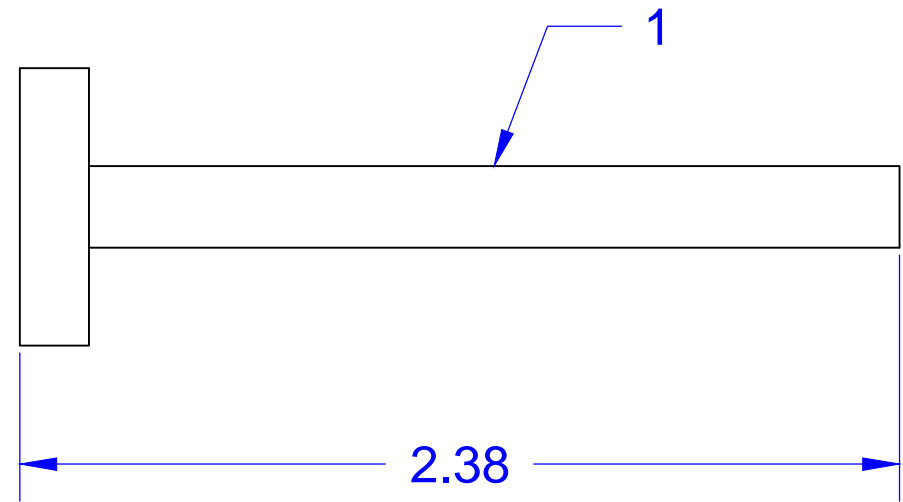
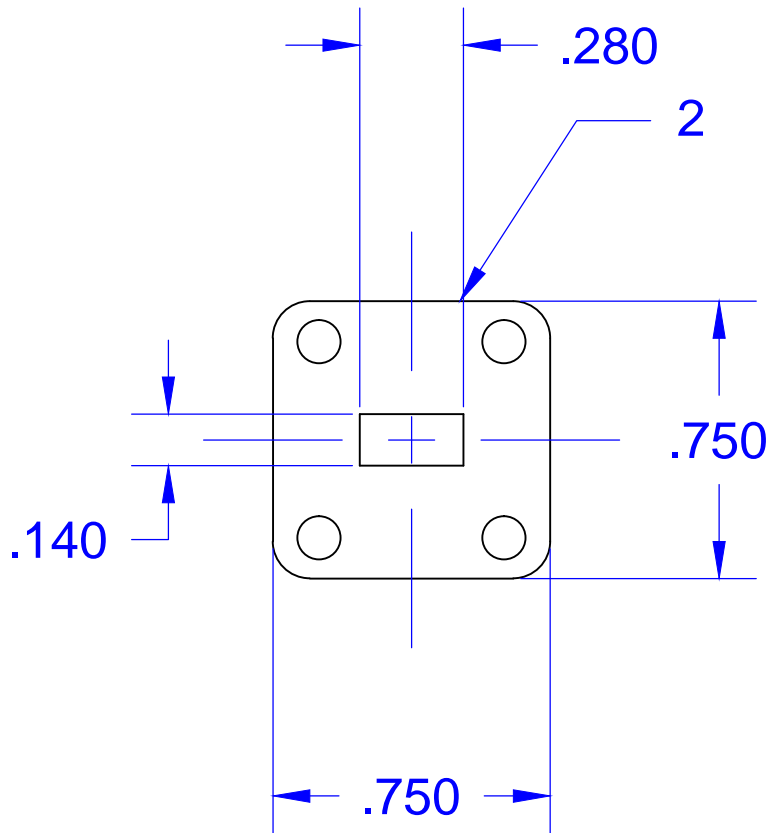
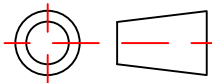

1	STOCK	UG599 FLANGE		2
1	STOCK	WR-28 WAVEGUIDE		1
QTY	PART NUMBER	DESCRIPTION		ITEM
UNLESS OTHERWISE SPECIFIED		 <p>THIRD ANGLE PROJECTION</p> <p>Mi-Wave Millimeter Products Inc.</p> <p>TITLE</p> <p>580A/599 TERMINATION OUTLINE</p>		
ALL SURFACES $\sqrt{32}$				
DIMENSIONS ARE IN INCHES				
TOLERANCES ARE:				
DECIMALS: .1234 +/- .0005		DRAFTING: MRN		
.123 +/- .005		APPROVED: M.S.		
.12 +/- .01		DATE: 7/15/2010		
ANGLES: +/- .5 DEGREES				
ALL THREADS TO BE 2A OR 2B				
REF DWG# --	SHEET NO.	OF	SIZE	DWG NO
ORIGINAL DWG# 20183	1	1	A	20306