

REVISIONS			
REV	DESCRIPTION	DATE	APPROVED
--	--	--	--

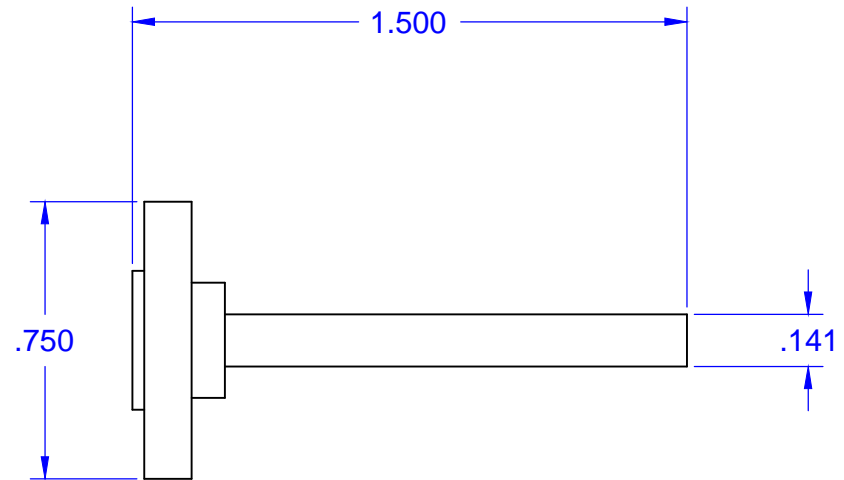
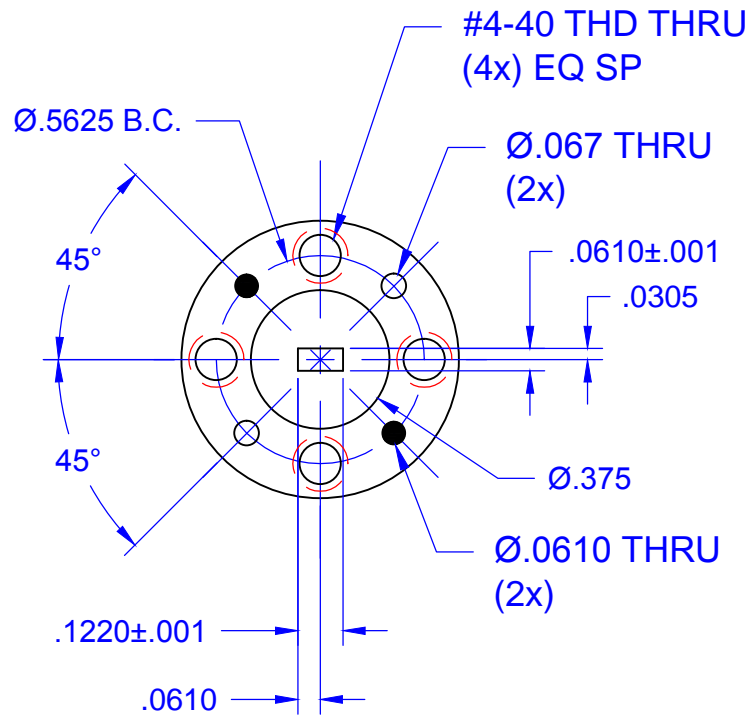
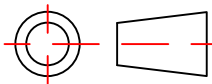

1	STOCK	UG387 FLANGE		2	
1	STOCK	WR-12 WAVEGUIDE		1	
QTY	PART NUMBER	DESCRIPTION	ITEM		
UNLESS OTHERWISE SPECIFIED ALL SURFACES $\sqrt{32}$		 THIRD ANGLE PROJECTION	Mi-Wave Millimeter Products Inc. TITLE 580E-387 OUTLINE		
DIMENSIONS ARE IN INCHES TOLERANCES ARE: DECIMALS: .1234 +/- .0005 .123 +/- .005 .12 +/- .01 ANGLES: +/- .5 DEGREES					DRAFTING: K.S. APPROVED: M.S. DATE: 5/28/2014
ALL THREADS TO BE 2A OR 2B		SHEET NO.	OF	SIZE	DWG NO
REF DWG# --		1	1	A	22367