

REVISIONS			
REV	DESCRIPTION	DATE	APPROVED
--	--	--	--

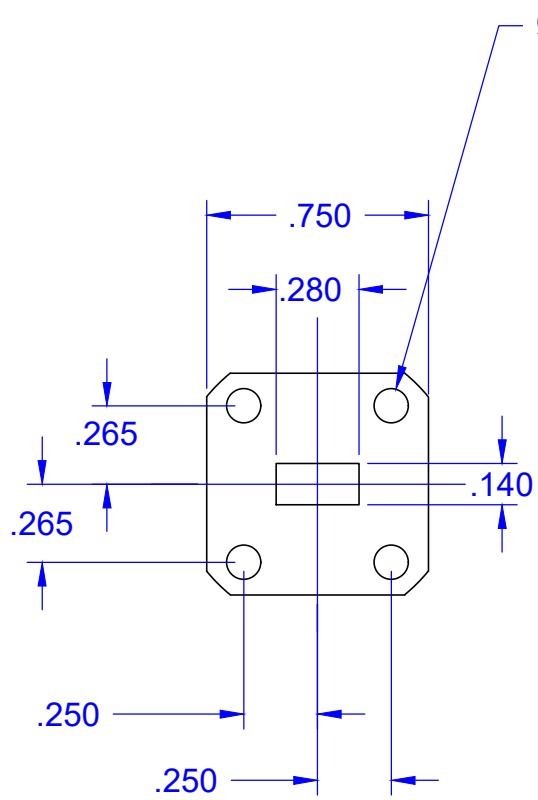

UG 599 FLANGE

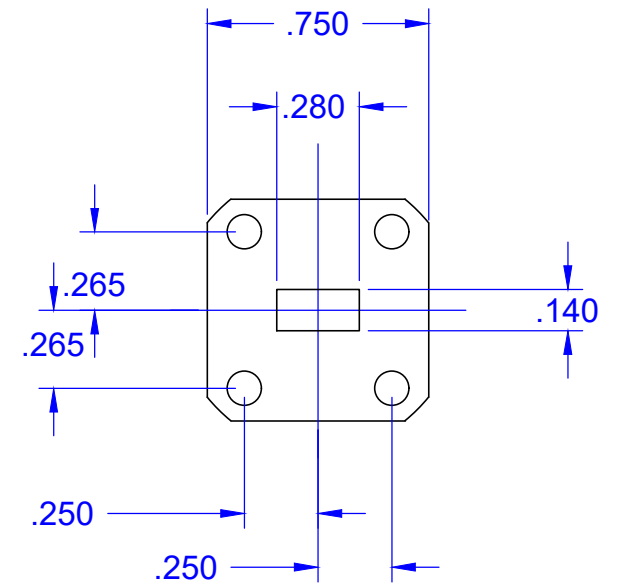
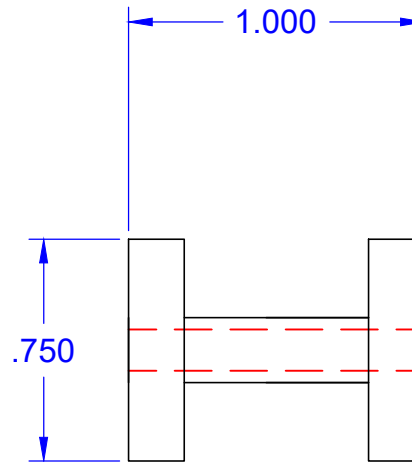

UG 599 FLANGE

QTY	PART NUMBER	DESCRIPTION		ITEM
UNLESS OTHERWISE SPECIFIED ALL SURFACES $\sqrt{32}$		<p>THIRD ANGLE PROJECTION</p>		<p><b>Mi-Wave</b> Millimeter Products Inc.</p> <p>TITLE</p> <p><b>690A-1.00/599 OUTLINE</b></p>
DIMENSIONS ARE IN INCHES TOLERANCES ARE:				
DECIMALS: .1234 +/- .0005 .123 +/- .005 .12 +/- .01				
ANGLES: +/- .5 DEGREES				
ALL THREADS TO BE 2A OR 2B		DATE: 2-6-19		
REF DWG# --		SHEET NO.	OF	SIZE
ORIGINAL DWG# 20016		1	1	A
		DWG NO		
		25873		