

REVISIONS			
REV	DESCRIPTION	DATE	APPROVED
--	--	--	--

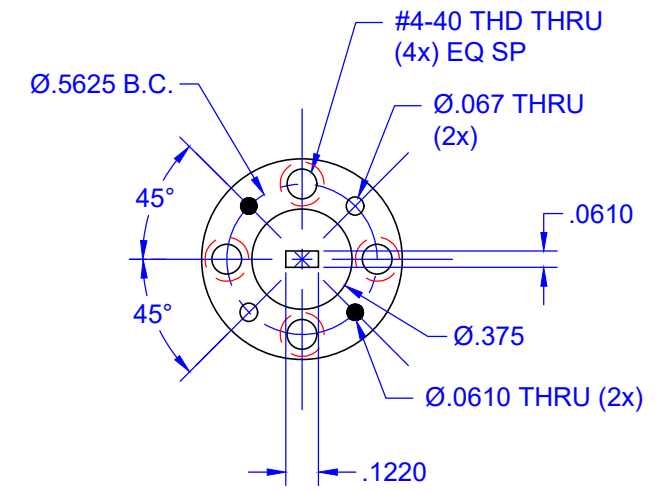
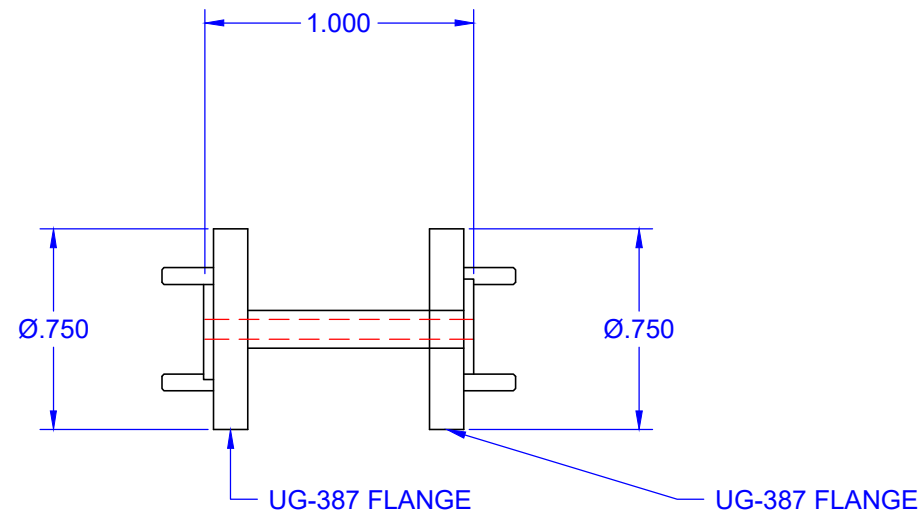
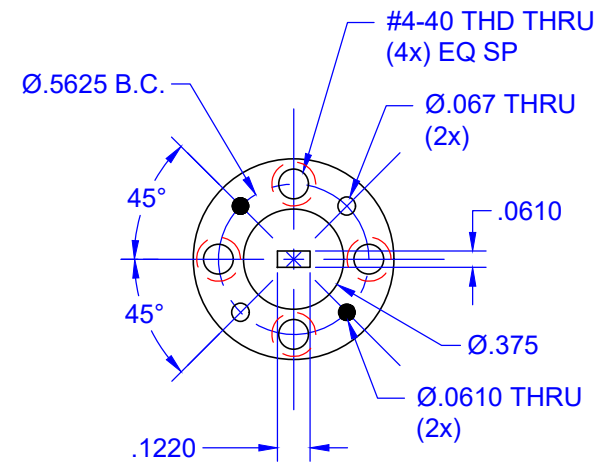

ALL DIMENSIONS ARE
REFERENCE ONLY

QTY	PART NUMBER	DESCRIPTION		ITEM
UNLESS OTHERWISE SPECIFIED ALL SURFACES $\sqrt{32}$		 THIRD ANGLE PROJECTION		Mi-Wave Millimeter Products Inc.
DIMENSIONS ARE IN INCHES TOLERANCES ARE: DECIMALS: .1234 +/- .0005 .123 +/- .005 .12 +/- .01 ANGLES: +/- .5 DEGREES		DRAFTING: C. C. APPROVED: M.S. DATE: 12/2/2016		TITLE 690E-1.00-387 OUTLINE
ALL THREADS TO BE 2A OR 2B		SHEET NO.	OF	SIZE
REF DWG #: 12171		1	1	DWG NO 25881