

REVISIONS			
REV	DESCRIPTION	DATE	APPROVED
--	--	--	--

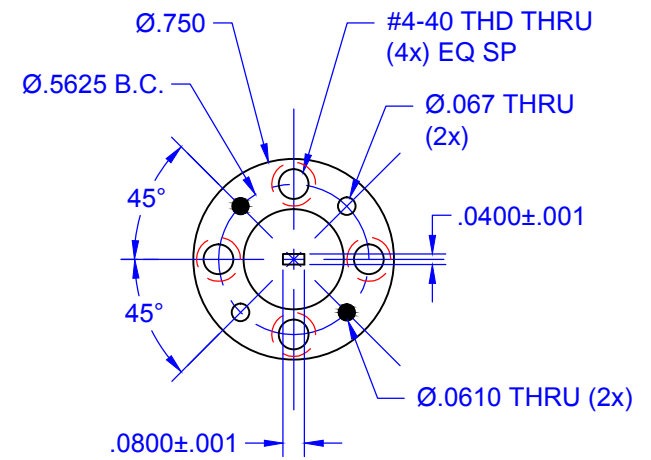
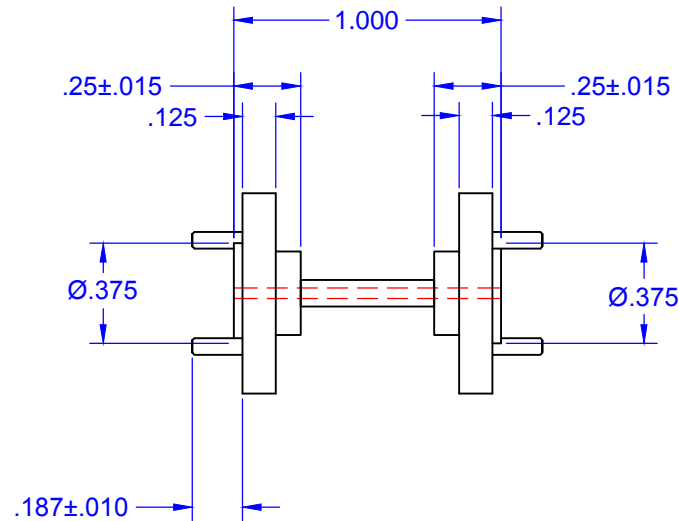
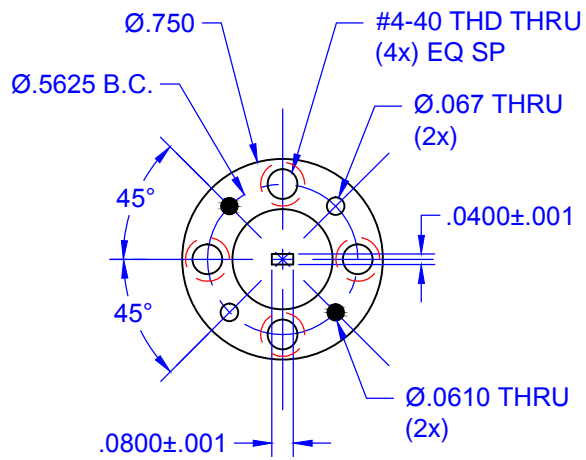

QTY	PART NUMBER	DESCRIPTION	ITEM
	UNLESS OTHERWISE SPECIFIED ALL SURFACES $\sqrt{32}$	 THIRD ANGLE PROJECTION	Mi-Wave Millimeter Products Inc.
	DIMENSIONS ARE IN INCHES TOLERANCES ARE: DECIMALS: $.1234 \pm .0005$ $.123 \pm .005$ $.12 \pm .01$ ANGLES: $\pm .5$ DEGREES	DRAFTING: CC APPROVED: M.S. DATE: 7-23-19	TITLE 690F-1.00/387 OUTLINE
	ALL THREADS TO BE 2A OR 2B REF DWG #: 12171	SHEET NO. 1 OF 1	SIZE A DWG NO 24835