

REVISIONS			
REV	DESCRIPTION	DATE	APPROVED
--	--	--	--

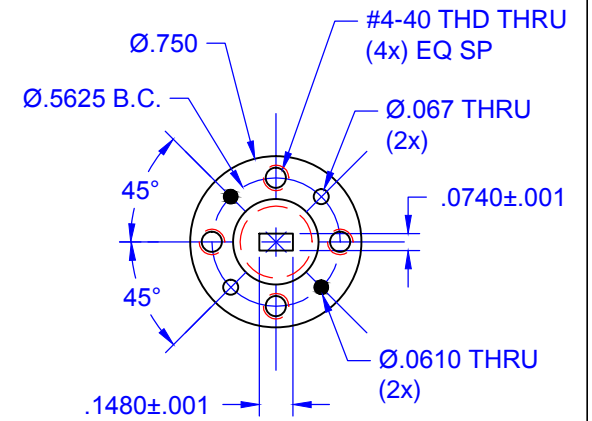
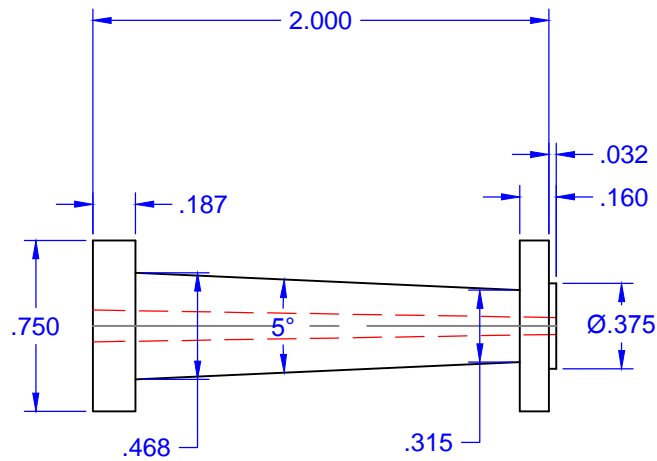
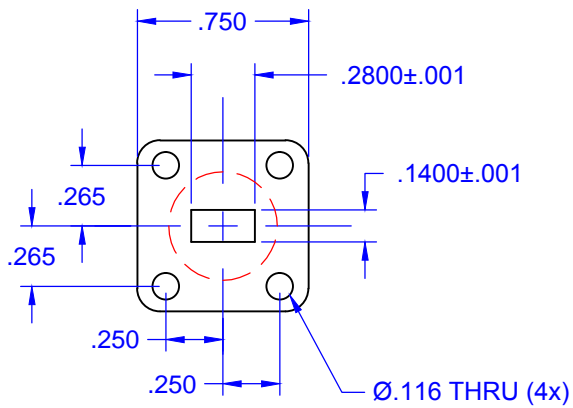

--	--	MATERIAL: 1/2 HARD BRASS		--
QTY	PART NUMBER	DESCRIPTION		ITEM
UNLESS OTHERWISE SPECIFIED ALL SURFACES $\sqrt{32}$		 THIRD ANGLE PROJECTION	Mi-Wave Millimeter Products Inc. TITLE 692A-V/599/385 MACHINE DWG	
DIMENSIONS ARE IN INCHES TOLERANCES ARE: DECIMALS: .1234 +/- .0005 .123 +/- .005 .12 +/- .01 ANGLES: +/- .5 DEGREES				
ALL THREADS TO BE 2A OR 2B		APPROVED: M.S.	DATE: 10/24/2013	
REF DWG# --		SHEET NO. 1	OF 1	SIZE A
ORIGINAL DWG# 20167				DWG NO 24960