

REVISIONS			
REV	DESCRIPTION	DATE	APPROVED
--	--	--	--

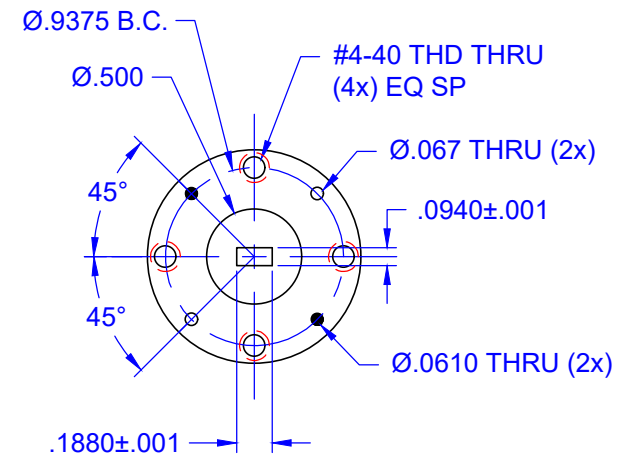
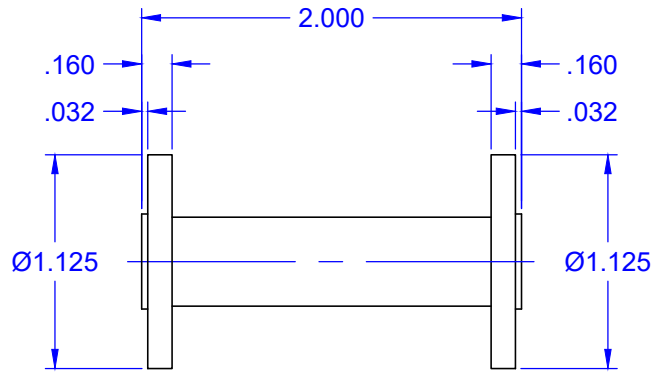
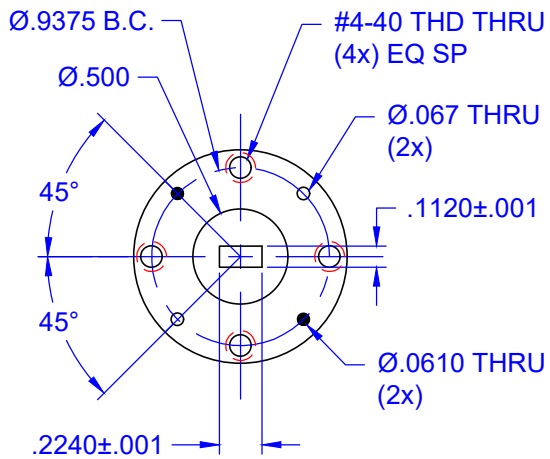
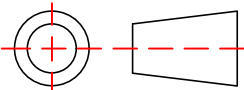

--	--	MATERIAL: 1/2 HARD BRASS		--	
QTY	PART NUMBER	DESCRIPTION		ITEM	
UNLESS OTHERWISE SPECIFIED ALL SURFACES $\sqrt{32}$		 THIRD ANGLE PROJECTION		<b>Mi-Wave</b> Millimeter Products Inc.  <b>692B-U/383</b> <b>OUTLINE</b>	
DIMENSIONS ARE IN INCHES TOLERANCES ARE: DECIMALS: .1234 +/- .0005 .123 +/- .005 .12 +/- .01 ANGLES: +/- .5 DEGREES		DRAFTING: MRN			
ALL THREADS TO BE 2A OR 2B		APPROVED: M.S.			
REF DWG# 14171		DATE: 3/2/2011			
		SHEET NO.	OF	SIZE	DWG NO
		1	1	A	25891