

REVISIONS			
REV	DESCRIPTION	DATE	APPROVED
--	--	--	--

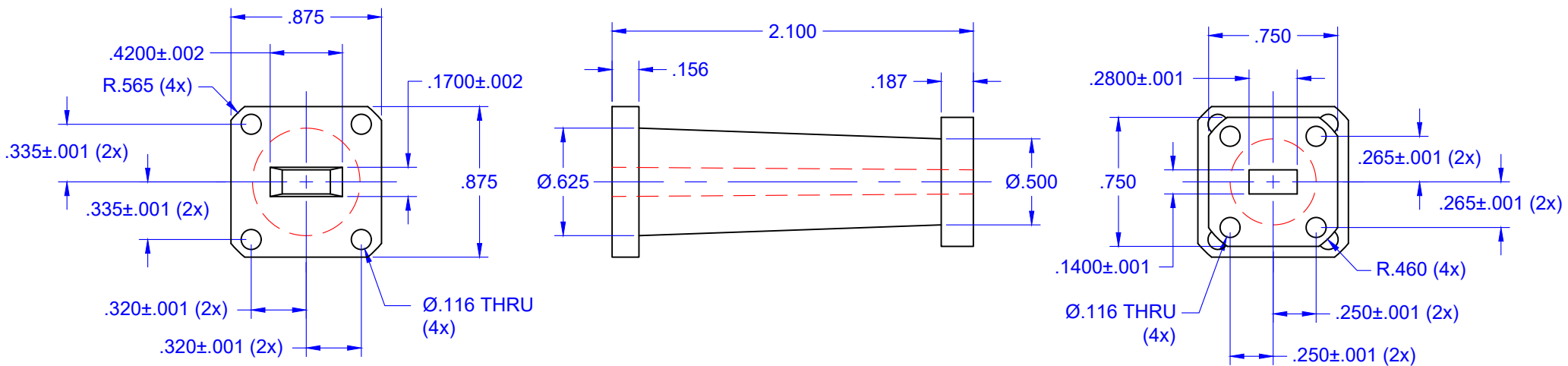
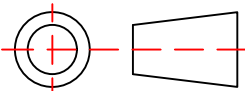

QTY	PART NUMBER	MATERIAL: 1/2 HARD BRASS		DESCRIPTION	ITEM
UNLESS OTHERWISE SPECIFIED		 THIRD ANGLE PROJECTION		<b>Mi-Wave</b> Millimeter Products Inc.  <b>692 K-A/595/599</b> <b>MACHINE DWG</b>	
ALL SURFACES 32/					
DIMENSIONS ARE IN INCHES					
TOLERANCES ARE:					
DECIMALS: .1234 +/- .0005		DRAFTING: MRN			
.123 +/- .005		APPROVED: M.S.			
.12 +/- .01		DATE: 12/16/2009			
ANGLES: +/- .5 DEGREES					
ALL THREADS TO BE 2A OR 2B					
REF DWG# --		SHEET NO.	OF	SIZE	DWG NO
ORIGINAL DWG# 20040		1	1	A	20077