

REVISIONS			
REV	DESCRIPTION	DATE	APPROVED
--	--	--	--

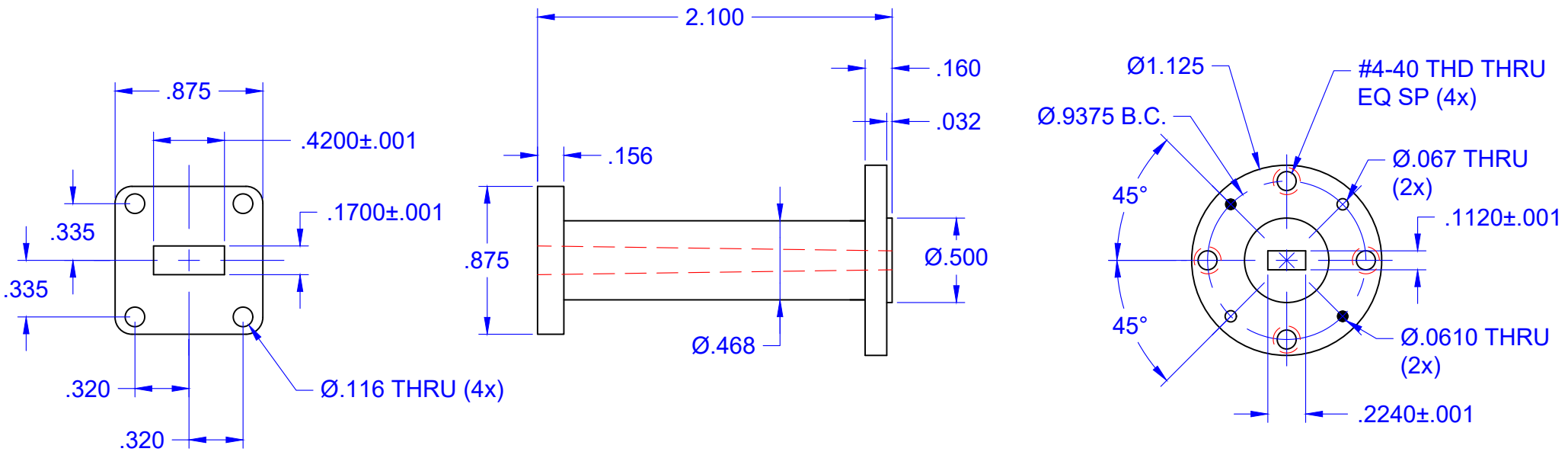

QTY	PART NUMBER	MATERIAL: 1/2 HARD BRASS		DESCRIPTION	ITEM
UNLESS OTHERWISE SPECIFIED ALL SURFACES $\sqrt{32}$		<p>THIRD ANGLE PROJECTION</p>		<p>Mi-Wave Millimeter Products Inc.</p> <p>TITLE</p> <p>692K-B/595/383 MACHINE DWG</p>	
DIMENSIONS ARE IN INCHES TOLERANCES ARE:					
DECIMALS: .1234 +/- .0005 .123 +/- .005 .12 +/- .01					
ANGLES: +/- .5 DEGREES					
ALL THREADS TO BE 2A OR 2B		DATE: 6/30/2010			
REF DWG# --		SHEET NO.	OF	SIZE	DWG NO
ORIGINAL DWG# 20166		1	1	A	20274