

REVISIONS			
REV	DESCRIPTION	DATE	APPROVED
--	--	--	--

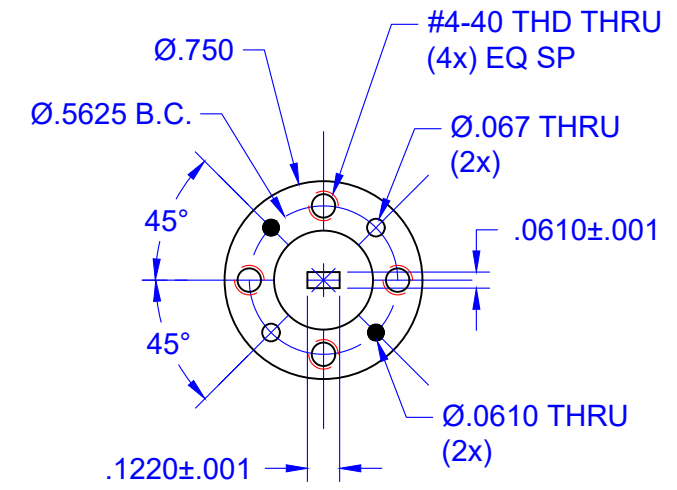
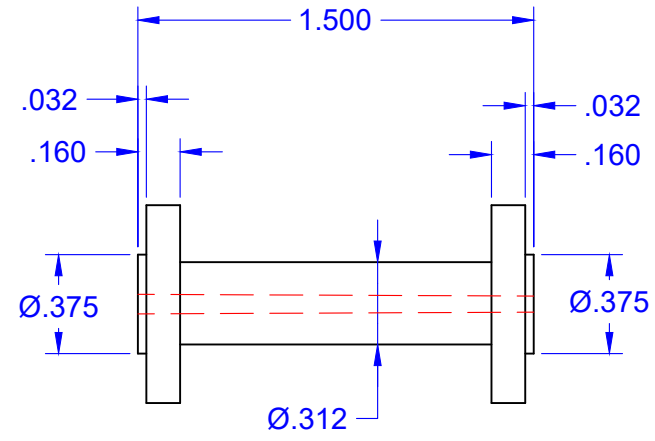
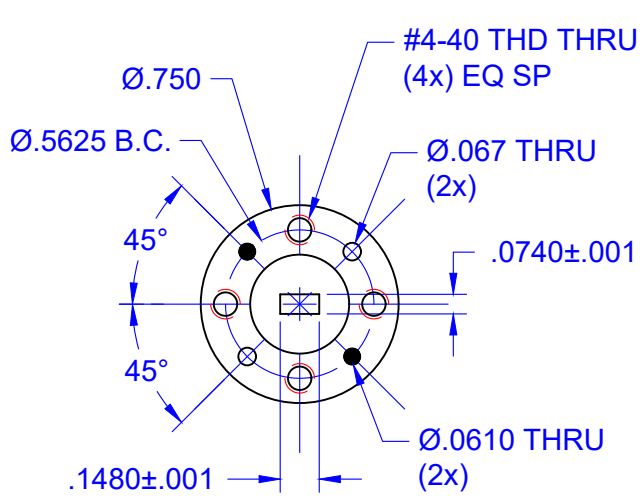

--	--	MATERIAL: 1/2 HARD BRASS		--
QTY	PART NUMBER	DESCRIPTION		ITEM
UNLESS OTHERWISE SPECIFIED ALL SURFACES $\sqrt{32}$		 THIRD ANGLE PROJECTION	<b>Mi-Wave</b> Millimeter Products Inc. TITLE <b>692V-E/385/387 MACHINE DWG</b>	
DIMENSIONS ARE IN INCHES TOLERANCES ARE: DECIMALS: $.1234 \pm .0005$ $.123 \pm .005$ $.12 \pm .01$ ANGLES: $\pm .5$ DEGREES				
ALL THREADS TO BE 2A OR 2B		DATE: 7/01/2010		
REF DWG# --		SHEET NO.	OF	SIZE
ORIGINAL DWG# 20168		1	1	DWG NO
				<b>A</b>
				<b>20278</b>