

| REVISIONS | | | |
|-----------|-------------|------|----------|
| REV | DESCRIPTION | DATE | APPROVED |
| -- | -- | -- | -- |

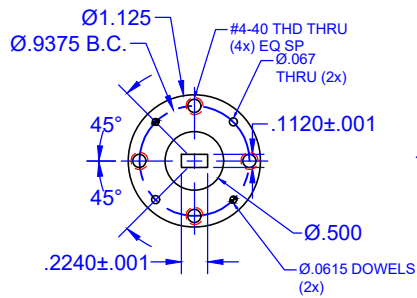

UG-383 FLANGE

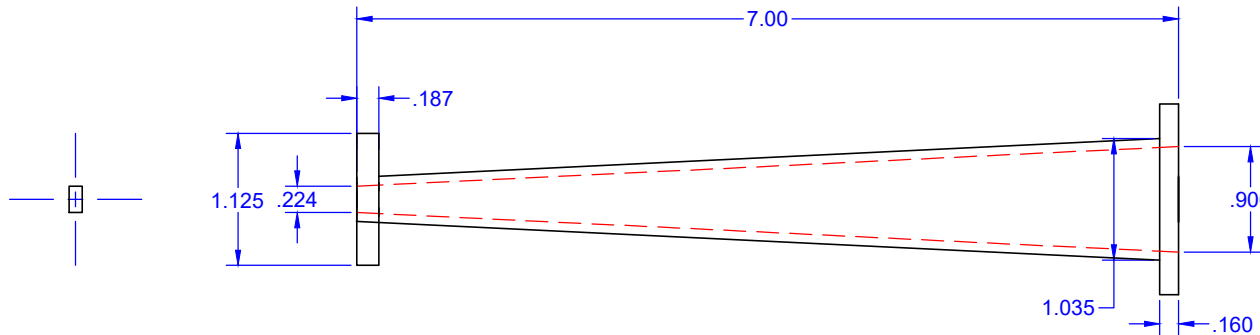
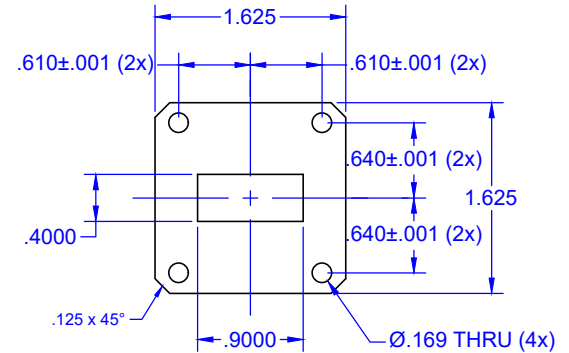
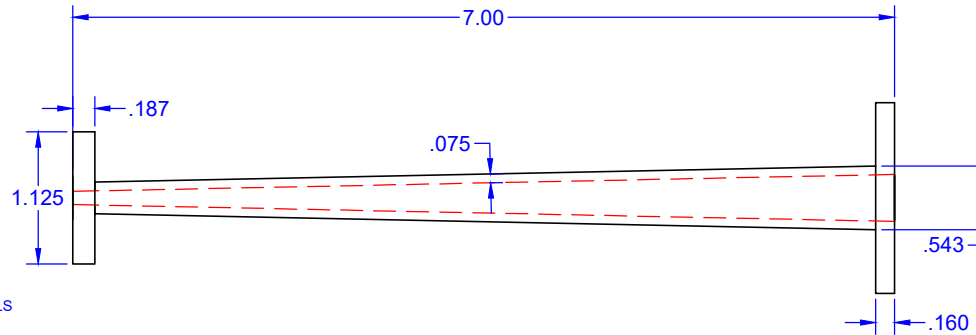

| | | | | |
|----------------------------|-------------|----------------------------|---|-------|
| -- | -- | MATERIAL: 6061-T6 ALUMINUM | | -- |
| QTY | PART NUMBER | DESCRIPTION | | ITEM |
| UNLESS OTHERWISE SPECIFIED | | THIRD ANGLE PROJECTION | Mi-Wave Millimeter Products Inc. 692X-B/39/383 MACHINE DWG | |
| ALL SURFACES $\sqrt{32}$ | | | | |
| DIMENSIONS ARE IN INCHES | | DRAFTING: C.C. | | TITLE |
| TOLERANCES ARE: | | APPROVED: M.S. | | |
| DECIMALS: .1234 +/- .0005 | | DATE: 8/10/2020 | | SIZE |
| .123 +/- .005 | | SHEET NO. 1 OF 1 | | |
| .12 +/- .01 | | DWG NO | | 25432 |
| ANGLES: +/- .5 DEGREES | | REF DWG# -- | | |
| ALL THREADS TO BE 2A OR 2B | | ORIGINAL DWG# 20087a | | |